

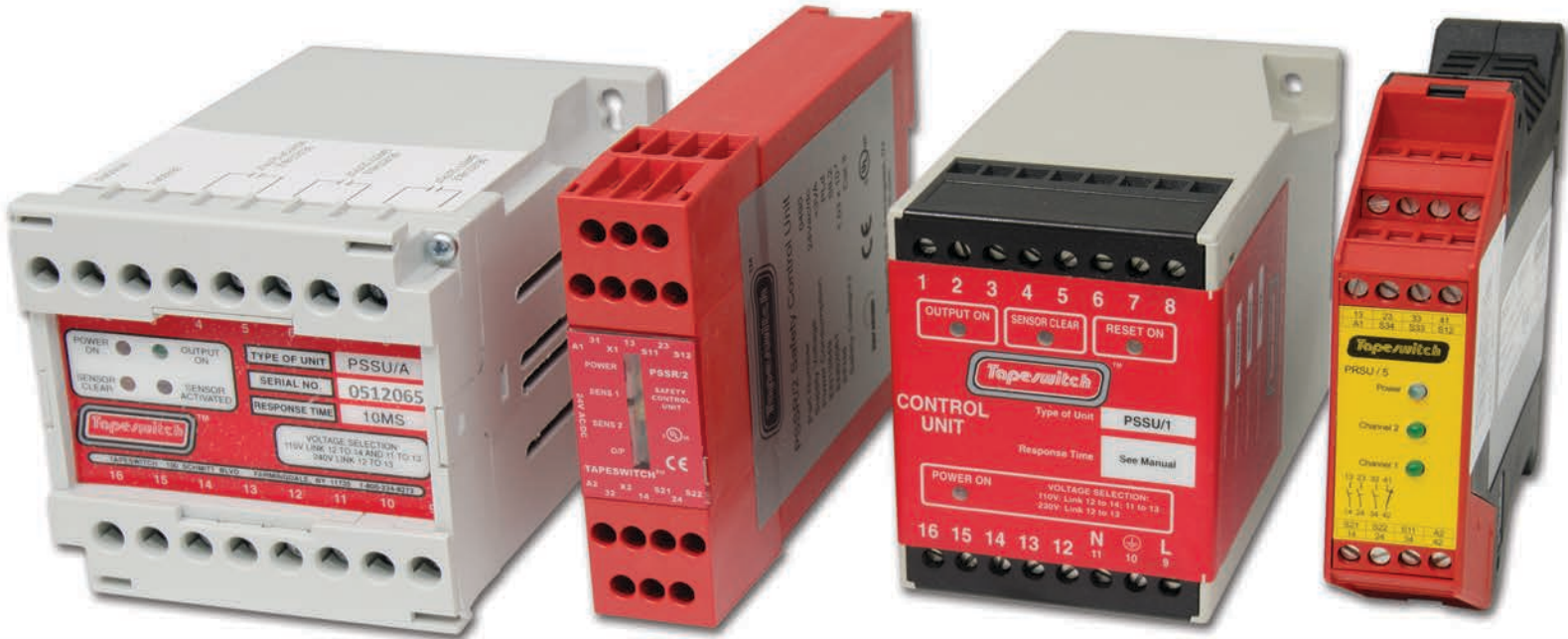

A full spectrum of sensing and signaling products for protection, detection, and safety



- SWITCH PRODUCTS
- SAFETY & SIGNAL MATS
- SENSING EDGES
- SENSING BUMPERS
- SAFETY INTERFACE MODULES
- LIGHT CURTAINS & LASER SCANNER
- CUSTOM DESIGNS
- SAFETY INTERLOCKS

Fail-Safe Interface Controllers

Connect ribbon switches, safety mats, sensing edges and bumpers to machine or process controls

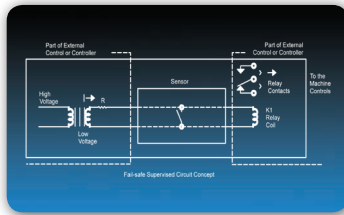

- pg.2 **Using Controllers in Safety Applications**
Understanding the fail-safe concept



- pg. 3 **PRSU Control Units**
Meet safety category 3, PLd as defined by EN ISO 13849-1
Accommodates 24 VDC or 110 VAC operation
Enclosure designed for DIN rail mounting



- pg.5 **PSSU Control Units**
Suitable for high-risk automation and machine control
100-240 VAC or 24 VDC
Wall mounting or DIN rail mounting models



- pg.7 **PSSR/2 Control Unit**
Meets safety category 3 as defined by EN13849-1:2006 PLd, EN62061 SIL2
24 VAC or VDC
End of the line resistor



- pg.9 **PCU Programmable Control Units**
SIL3 EN61496-1
240 VDC
Suitable for most machine guarding products

While every effort has been made to ensure the accuracy of the information provided, no liability can be taken for any errors or omission. Tapeswitch Corporation reserves the right to alter specifications and introduce improvements without prior notice.

USING CONTROLLERS IN SAFETY APPLICATIONS

Understanding the fail-safe concept

Tapeswitch sensing mat, edges, and bumpers often provide the first-line of protection for personnel and equipment. They are highly sensitive and feature press-at-any-point actuation. Properly installed and connected, they continuously monitor contact. However, to properly function as safety devices, they must be installed with a fail-safe monitoring circuit as shown below or with an equivalent fail-safe methodology. **Tapeswitch Controllers Employ this Fail-Safe Concept.**

Understanding and Implementing the 4 conductor fail-safe concept

The fail-safe concept monitors the sensor status at all times. In the event of a failure, the fail-safe concept will simulate a protected position. The “protected” position is when the sensor is activated (closed) and the “normal” or “run” position is when the sensor is not activated (open).

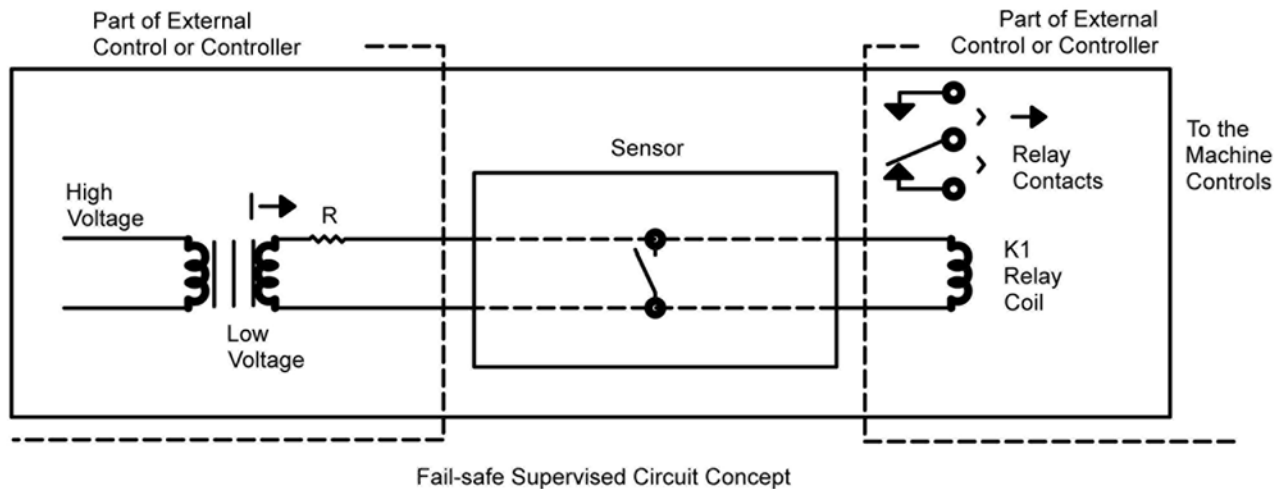

- Normal Conditions – constant current flow (I) holding relay coil (K1) energized
- Loss of Power – no current flow (I) and relay coil (K1) is de-energized
- Actuation of Sensor – relay coil (K1) is shorted and de-energized
- Failure of Sensor in the closed position – relay coil (K1) is shorted and de-energized
- Failure of Sensor in the open position – (broken wire, severed switch or conductor) leaves no path for current flow (I) and relay coil (K1) is de-energized
- Resistor R – limits current flow through the sensor when actuated

Fail-safe (4 conductor)

Fail-safe is a shorthand term used to mean fail to a safe condition. In machinery with known hazards, the system is fail-safe when any failure leaves the machinery in a safe condition. The 4 conductor fail-safe concept is illustrated in the figure above. A small current is constantly flowing through the sensor at all times, holding the relay coil energized at all times. The machine controls, interrupt, or stop circuitry is connected to the contacts of this relay. If the sensor is actuated, the relay coil will be shorted, causing the relay to de-energize. A resistor in series provides current limiting from overdrawing the power supply and limits the current through the sensor in the actuated position. If the sensor fails in the closed position the relay will be shorted and cannot be energized until the failure is corrected. If the sensor fails in the open position, the current path for the relay coil no longer exists and the relay coil cannot be energized until the current path is restored and the failure corrected.

In addition to the safety aspects achieved with fail-safe, it also provides:

- Isolation of the machine controls and sensor(s)
- Isolation of high amperage and high voltage machine switching from the low voltage sensors
- Conversion of a normally open switch to required normally closed machine controls

While every effort has been made to ensure the accuracy of the information provided, no liability can be taken for any errors or omission. Tapeswitch Corporation reserves the right to alter specifications and introduce improvements without prior notice.



PRSU/4 & PRSU/5 Control Units

PRSU Control Units can be used as safety devices for high-risk automation and machine control applications. They provide the highest level of safety offered by Tapeswitch, exceeding the requirements of category 3 as defined by EN ISO 13849-1: 2006. They also meet or exceed the safety content of the applicable OSHA, ANSI, and RIA Standards.

The PRSU Controller has redundant safety output relays, is self-monitoring, and is rated Control Reliable, which means that any fault in the safety-critical components will be detected and the machine will be rendered inoperative until the fault is corrected. It is available in a DIN rail-mounted package. The unit features both manual and auto reset capability.



Applications

PRSU Control units are designed to be used with Tapeswitch pressure sensitive sensors to form a complete safety system. They are compatible with all Tapeswitch sensing products, including ribbon switch, safety mats, sensing edges, and bumpers.

Features & Benefits

- Suitable for high-risk automation and machine control
- Self-monitoring design detects faults anywhere in the safety system components
- Meets or exceeds OSHA, ANSI, & RIA safety standards
- Automatic or manual reset capability
- DIN rail mounting

General Specifications

Tested In Accordance With	EN ISO 13849-1: 2006
Achieved Level/Category	PLd, Cat 3
Supply Voltage	24 VDC / VAC (PRSU/4) 115 VAC (PRSU/5)
Power Consumption	5 VA / 3 W (PRSU/4) 5 VA (PRSU/5)
Response Time	< 30 ms
Enclosure Type	DIN rail mounting
Reset Mode	Automatic or manual (user selected)
Output Relays	Force guided safety relays, 3 x N/O monitor relay, 1 x N/C

PRSX/4 Expansion Module

Tapeswitch model PRSX/4 Expansion Module is designed to use with Tapeswitch controllers. The expansion module can be used for both sensing controllers and light curtain controllers. The PRSX/4 Expansion module increases the number of normally open force guided contacts by 4. An additional normally closed feedback relay is also provided. Several expansion modules may be connected to one controller.

While every effort has been made to ensure the accuracy of the information provided, no liability can be taken for any errors or omission. Tapeswitch Corporation reserves the right to alter specifications and introduce improvements without prior notice.

PRSU Dimensions

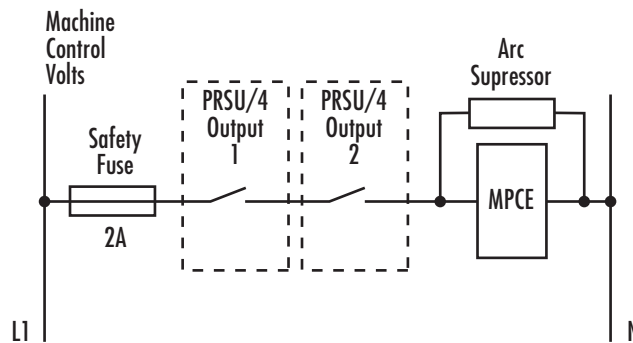
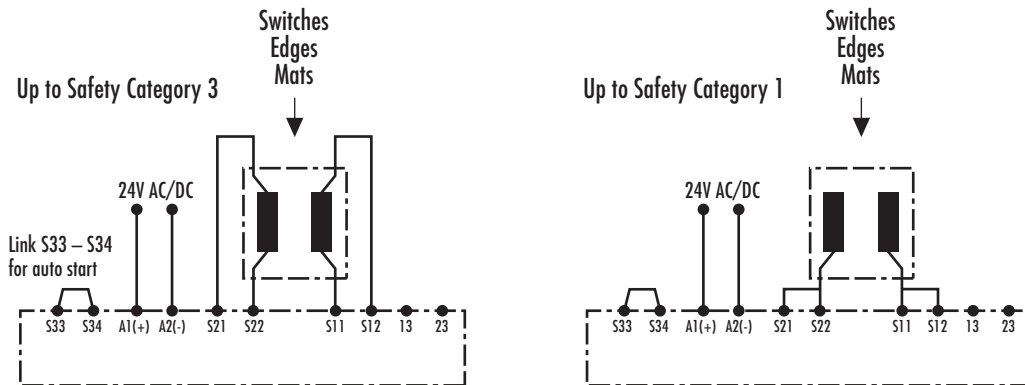
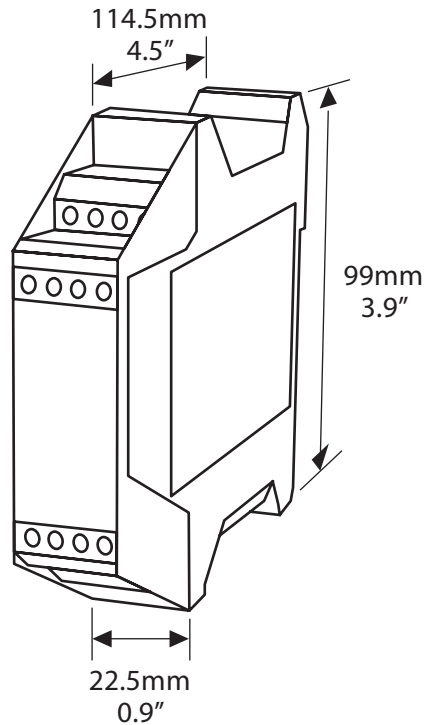

Preferred wiring scheme for PRSU to primary control element (MPCE)

While every effort has been made to ensure the accuracy of the information provided, no liability can be taken for any errors or omission. Tapeswitch Corporation reserves the right to alter specifications and introduce improvements without prior notice.

PSSU CONTROL UNITS

PSSU Series Control Units

The PSSU series of controllers can be used as safety devices for high-risk automation and machine control applications. They provide the highest level of safety offered by Tapeswitch, exceeding the requirements of Category 3 as defined by EN 954-1, and meeting or exceeding the safety content of the applicable OSHA, ANSI, and RIA Standards.

PSSU controllers have redundant safety output relays, are self-monitoring, and are rated Control Reliable, which means that any fault in the safety-critical components will be detected and the machine will be rendered inoperative until the fault is corrected.



**DIN Rail Mounted
PSSU/1, PSSU/2**



**Wall Mounted
PSSU/3, PSSU/4**



**DIN Rail Mounted
PSSU/A, PSSU/A2**

Features & Benefits

- Suitable for high-risk automation and machine control
- Self-monitoring design detects faults anywhere in the safety system components
- Meets or exceeds OSHA, ANSI, & RIA safety standards
- Automatic and manual reset versions
- Wall mounting or DIN rail mounting models

General Specifications

Model	PSSU/1	PSSU/2	PSSU/3	PSSU/4	PSSU/A	PSSU/A2
Supply Voltage	110/240 VAC 50/60 Hz	24 VDC	110/240 VAC 50/60 Hz	24 VDC	110/240 VAC 50/60 Hz	24 VDC
Power Consumption	6 VA	6 VA	6 VA	6 VA	6 VA	15 VA
Mounting	DIN Rail	DIN Rail	Wall	Wall	DIN Rail	DIN Rail
Reset Mode		Manual (Remote)			Auto Reset	Auto Reset
Output Relay	2 x Safety Relays (force-guided contacts), Cross-monitored					
Output Contact Rating	6 A @ 240 V, Resistive, Non-Inductive					
Applications	Medium to High Risk Safety (Level of Risk Determined by Sensor)					
Safety Standard	Up to Level 2: DIN 31006-1, Level 2.2: DIN 31006, Category 3: EN 954-1 Control Reliable, Self-monitoring, UL and cUL listed					

While every effort has been made to ensure the accuracy of the information provided, no liability can be taken for any errors or omission. Tapeswitch Corporation reserves the right to alter specifications and introduce improvements without prior notice.

PSSU Dimensions

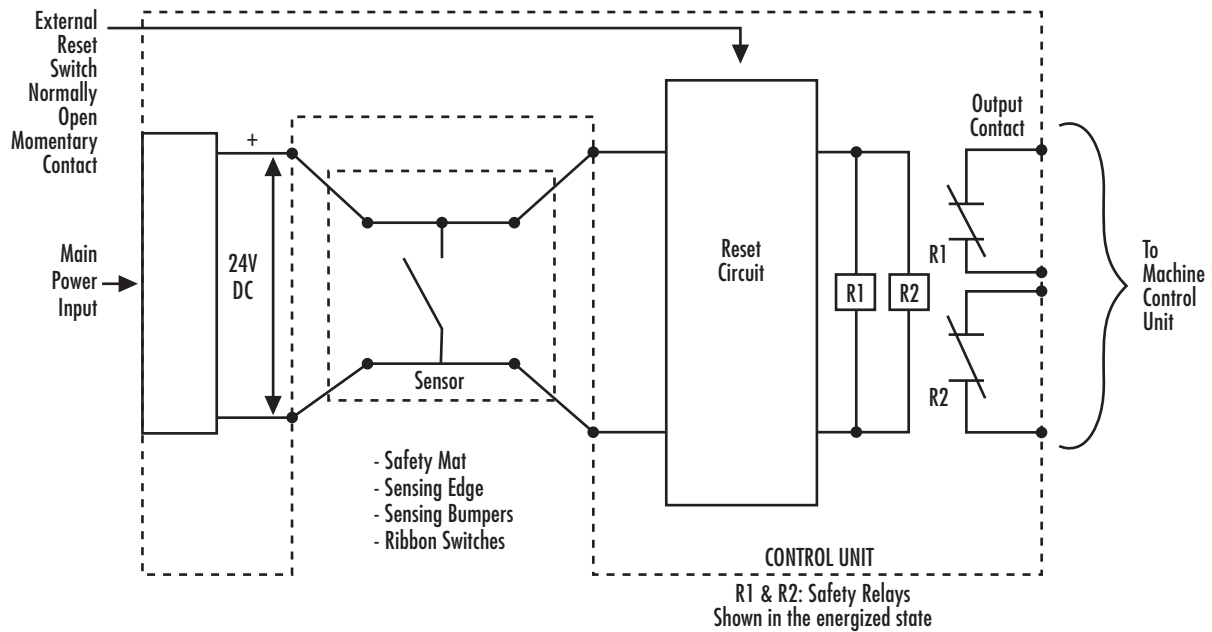
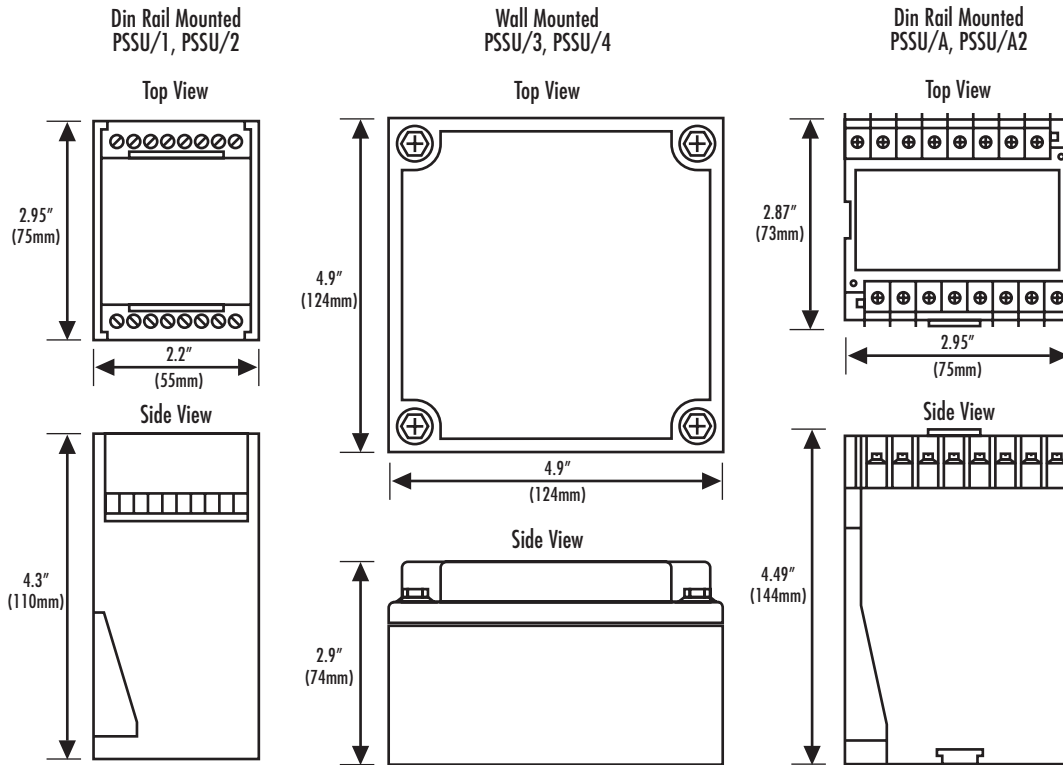

While every effort has been made to ensure the accuracy of the information provided, no liability can be taken for any errors or omission. Tapeswitch Corporation reserves the right to alter specifications and introduce improvements without prior notice.

PSSR/2 Control Unit

The PSSR/2 control unit is designed to be used in conjunction with Tapeswitch pressure sensitive sensor products to make a complete safety system. Sensors may take the form of safety mats, sensing edges, bumpers, or ribbon switches but must incorporate an integral end of the line resistor.

When the PSSR/2 is used with suitable Tapeswitch sensing edges, bumpers, switches or mats the system meets the requirements of EN13849-1:2006 PLd, EN62061 SIL2 and is a Category 3 configuration. It is an extremely compact unit which has a 22.5 mm DIN rail enclosure ideal for mounting in control panels. The PSSR/2 has a manual or auto reset function and operates from 24 VDC.



Features & Benefits

- Works with all mats, edges, bumpers, and switches
- Category 3 PLd SIL2
- End of line resistor monitoring
- DIN rail mounted
- 24 VDC supply voltage
- Manual or auto reset
- Self-monitoring
- 3 Output contacts

General Specifications

Safety Performance Level	Category 3, PLd (EN13849-1:2008)	
Probability Of Dangerous Failures Per Hour (PFHd)	1.03 x 10 ⁻⁷	
Power Consumption	< 5 VA	
Response Time	13 ms	
Temperature Range	14 to 131°F (-10 to 55°C)	
Reset Function	Auto or Manual	
Supply Voltage	24 VAC or VDC	
Safety Outputs	Device Type	Safety relay, Force guided relays
	Contacts	2 x N/O, 1 x N/C
	Rating	(monitor) 5 A @ 240 VAC
Maximum Sensor Length	100 M (330 ft.)	
Enclosure Protection Rating	IP20	
Dimensions	3.31 in. high x 4.68 in. length x .88 in. wide	

While every effort has been made to ensure the accuracy of the information provided, no liability can be taken for any errors or omission. Tapeswitch Corporation reserves the right to alter specifications and introduce improvements without prior notice.

PSSR Dimensions

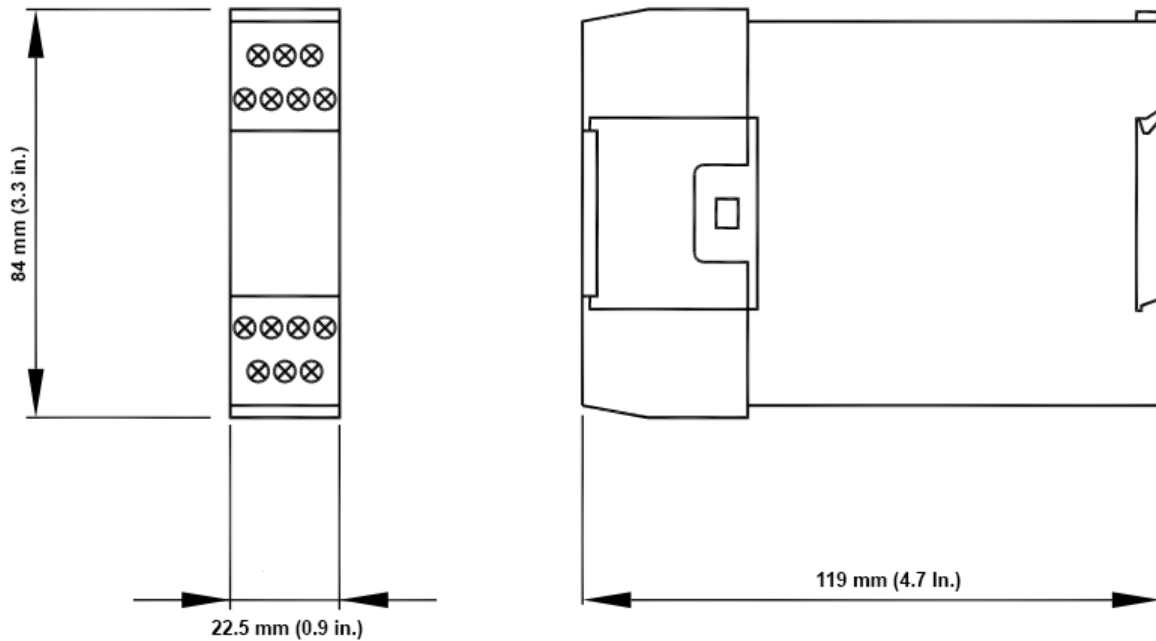

Single switch, 2-wire configuration, integrated Resistor

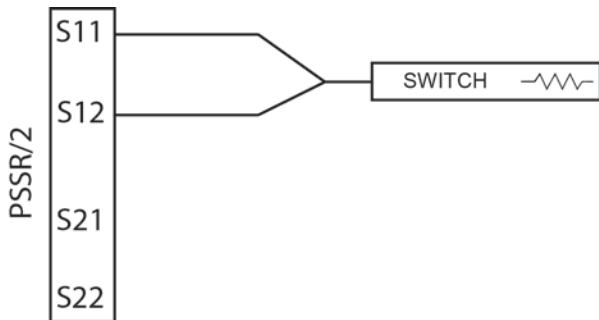

Multiple switch, 2-wire configuration, intergrated resistor

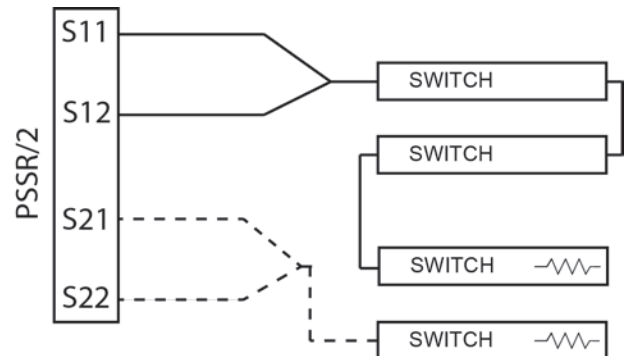

Two switch, 2-wire configuration, intergrated Resistor

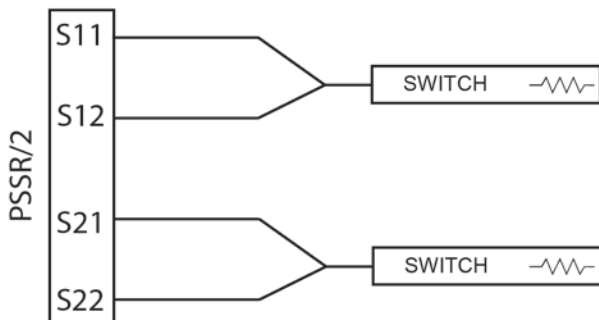

While every effort has been made to ensure the accuracy of the information provided, no liability can be taken for any errors or omission. Tapeswitch Corporation reserves the right to alter specifications and introduce improvements without prior notice.

PCU SERIES CONTROL UNITS

PCU/1 Control Unit

PCU/1 is a modular, configurable safety controller for protecting machines and plants. PCU/1 is capable of monitoring several safety sensors and products, such as safety light curtains, safety edges, safety bumpers, ribbon switches, laser scanners, photocells, mechanical switches, mats, emergency stops, two-handed controls, concentrating management of these in a single, flexible device.

The PCU software, installed on a PC, can be used to create complex logical conditions using logical operators and safety functions, such as muting, timer, counters, memories, etc. via an easy, intuitive graphic configuration interface. Configuration data are transferred to the PCU/1 unit via a USB link. Expansion modules are available for larger installations.



Features & Benefits

- Reduces the number of components and thus reduces footprint and wiring
- Promotes faster electrical cabinet construction
- Affords the necessary logical configuration using a single, simple programming software, facilitating modifications by machine designers
- Makes it possible to set up tamper-proof safety systems
- Simplifies machine maintenance through the MCM memory card, which can be used to transfer the configuration program to a new PCU/1 in just a few simple steps.

PCU Dimensions

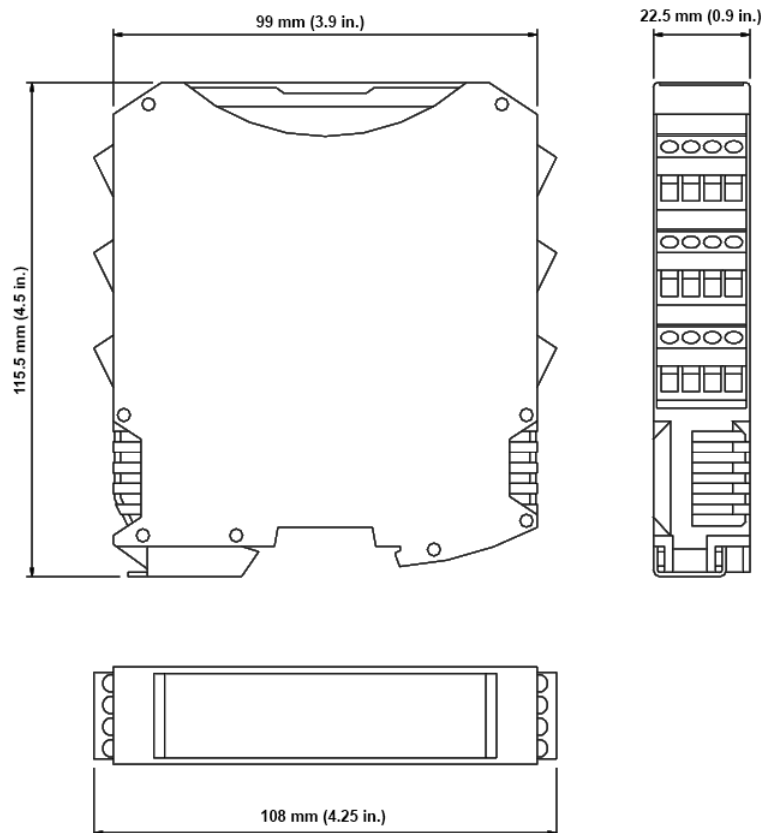

While every effort has been made to ensure the accuracy of the information provided, no liability can be taken for any errors or omission. Tapeswitch Corporation reserves the right to alter specifications and introduce improvements without prior notice.

General Specifications

Parameter	Value	Standard
PFH _d	See the technical data tables for each module	IEC 61508:1998
SIL	3	IEC 61508:1998
SILCL	3	IEC 62061:2005
Type	4	EN 61496-1
PL	e	ISO 13849-1:2006, IEC 62061:2005
D _{cavg}	High	ISO 13849-1:2006, IEC 62061:2005
MTTF _d (years)	30 ÷ 100	ISO 13849-1:2006, IEC 62061:2005
Category	4	ISO 13849-1:2006, IEC 62061:2005
Device Lifetime	20 years	ISO 13849-1:2006, IEC 62061:2005
Pollution Degree	2	
Max Number Of Inputs	128	
Max Number Of Outputs	16	
Max Number Of Slave Units (excluding PCU2SR/1 - PCU4SR/1)	14	
Max Number Of Slave Units Of the Same Type (excluding PCU2SR/1 - PCU4SR/1)	4	
Rated Voltage	24 VDC ± 20% / Supply from class II (LVLE)	
Over Voltage Category	II	
Digital INPUTS	PNP active high (EN 61131-2)	
OSSD (PCU/1, PCU812/1 PCU2E/1, PCU4E/1)	PNP active high - 400 mA @ 24 VDC max (each OSSD)	
Digital OUTPUTS	PNP active high - 100 mA @ 24 VDC max	
Response Time (ms)	Master	10,6 ÷ 12,6 + T _{Input_filter}
	PCU + 1 Slave	11,8 ÷ 26,5 + T _{Input_filter}
	PCU + 2 Slave	12,8 ÷ 28,7 + T _{Input_filter}
	PCU + 3 Slave	13,9 ÷ 30,8 + T _{Input_filter}
	PCU + 4 Slave	15 ÷ 33 + T _{Input_filter}
	PCU + 5 Slave	16 ÷ 35 + T _{Input_filter}
	PCU + 6 Slave	17 ÷ 37,3 + T _{Input_filter}
	PCU + 7 Slave	18,2 ÷ 39,5 + T _{Input_filter}
	PCU + 8 Slave	19,3 ÷ 41,7 + T _{Input_filter}
	PCU + 9 Slave	20,4 ÷ 43,8 + T _{Input_filter}
	PCU + 10 Slave	21,5 ÷ 46 + T _{Input_filter}
	PCU + 11 Slave	22,5 ÷ 48,1 + T _{Input_filter}
	PCU + 12 Slave	23,6 ÷ 50,3 + T _{Input_filter}
	PCU + 13 Slave	24,7 ÷ 52,5 + T _{Input_filter}
PCU + 14 Slave	25,8 ÷ 54,6 + T _{Input_filter}	
PCU/1 > Module Connection	proprietary 5-pole bus (PCUECI/1)	
Connection Cable Cross-Section	0,5 ÷ 2,5 mm ² / AWG 12 ÷ 30 (solid/stranded)	
Max Length Of Connections	100 M	
Operating Temperature / Relative Humidity	-10 ÷ 55°C / 10% ÷ 95%	

This response times depends on the following parameters:

- 1) Number of slave modules installed
- 2) Number of operators
- 3) Number of OSSD outputs

For the right response time refer to the one calculated by the PCU software (see Project report)

Some of the industries we serve.

Industrial Plant Maintenance Stamping Lock out **Area Guarding**

Metalworking **Plant Safety Military** Material Handling Signaling

Fabricating Manufacturing **Robotics** Process Control **OEM's**

Packaging Aerospace Public Safety Gaming **Sensing** Medical

Machine Guarding Monitoring Entertainment Access Control

Emergency Response **Transportation** Amusement Parks

Motion Sensing Monitoring Counting **Machine Control** Security



800-234-8273

Tapeswitch Corporation

100 Schmitt Boulevard, Farmingdale, NY 11735

www.tapeswitch.com • sales@tapeswitch.com

Tel: 631.630.0442 • Fax: 631.630.0454

